

# SR1054

## ROUGH TERRAIN TELEHANDLER



- Full-time 4 wheel drive
- Fully enclosed cab
- Power assisted steering
- Proportional joystick
- Simple to operate & maintain

 **snorkel**™  
[www.snorkellifts.com](http://www.snorkellifts.com)

# ROUGH TERRAIN TELEHANDLER

# SR1054

## CAPABILITIES SR1054

Max. lift capacity	10,000 lbs
Max. lift height (A)	53 ft 9 in
Max. forward reach	41 ft 4 in

## DIMENSIONS

Overall width (B)	7 ft 6 in
Stowed height (C)	8 ft 5 in
Length to fork face (D)*	21 ft 8 in
Wheelbase	9 ft 8 in
Ground clearance	14 in

## PERFORMANCE

Max. drive speed	18.7 mph
Raise/lower time	16/10.8 sec
Frame leveling	11°
Hydraulic flow (per minute)	32 gallons
Hydraulic pressure	3,336 psi
Hydraulic oil capacity	39.5 gallons
Fuel capacity	31.7 gallons
Outside turning radius	13 ft 8 in
Tires	445/65 - 22.5"

## POWER

Power source Deutz TCD 3.6L Tier 4 Final diesel 100 hp

## WEIGHT

Weight 26,852 lbs

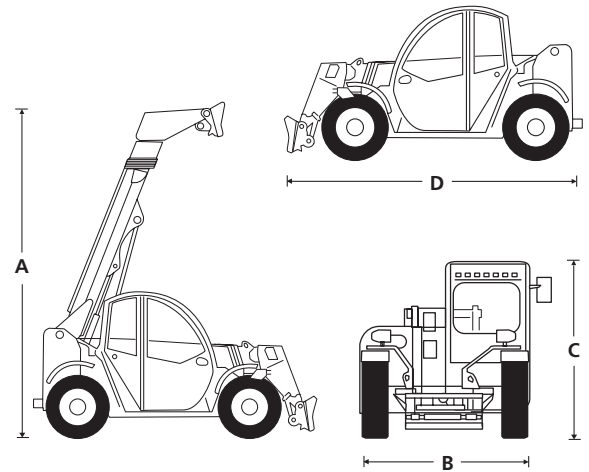

## STANDARD FEATURES

- Fully enclosed cab with air conditioning & heat
- Window wipers
- Running lights
- Manual pintle hitch
- Backup alarm
- PEB electrical boom socket
- Constant hydraulic flow
- Heater plug
- B class carriage adapter
- Hydraulic attachment quick disconnect
- LED front and rear work lights (4)
- LED work lights on boom (2)
- Axle mounted outriggers
- 2 year parts & labor, 5 year structural warranty
- ANSI compliant

## OPTIONS

- Special paint colors
- Multiple options for carriages, tires, fork tines and attachments

## LOAD CHART

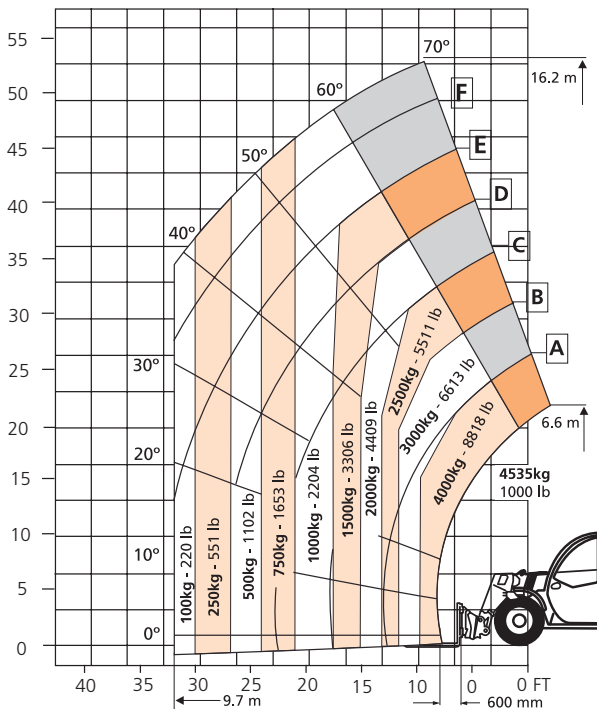

**snorkel** [www.snorkellifts.com](http://www.snorkellifts.com)

P.O. Box 1160  
 St. Joseph, MO 64502-1160, USA  
 Tel: 1 (785) 989-3000  
 Toll-free: 1 (800) 255-0317  
 Fax: 1 (785) 989-3070  
 Email: sales.usa@snorkellifts.com