

S9033RT/S9043RT/S9053RT

LARGE DECK, ROUGH TERRAIN SCISSOR LIFTS



- Large deck rough terrain scissor lifts
- Excellent rough terrain performance
- Easy to operate
- Heavy duty design
- Ideal for construction applications

 **snorkel**TM
www.snorkellifts.com

LARGE DECK, ROUGH TERRAIN SCISSOR LIFTS

S9033RT/ S9043RT/S9053RT

DIMENSIONS	S9033RT*	S9043RT*	S9053RT*
Max. working height	39 ft	49 ft	59 ft
Max. platform height (A)	33 ft	43 ft	53 ft
Platform size (stowed)	11 ft 9 in x 7 ft 6 in		
Platform size (single deck extended)	16 ft 3 in x 7 ft 6 in		
Platform size (dual deck extended)	22 ft x 7 ft 6 in		
Extension deck length	4 ft 6 in	4 ft 6 in	4 ft 6 in
Overall width (B)	7 ft 6 in	7 ft 6 in	7 ft 6 in
Overall length (C)	12 ft 1 in	12 ft 1 in	12 ft 1 in
Stowed height (D)	9 ft 2 in	9 ft 10 in	10 ft 6 in
Min. height (guardrails folded)	6 ft 6 in	7 ft 2 in	7 ft 8 in
Ground clearance	15 in	15 in	15 in

PERFORMANCE	S9033RT*	S9043RT*	S9053RT*
Platform capacity (SWL)	2,500 lbs	1,500 lbs	1,500 lbs
Max. drive height	32 ft	43 ft	30 ft
Max. wind speed	28 mph	28 mph	28 mph
Max. drive speed (stowed)	4.2 mph	4.2 mph	4.2 mph
Max. drive speed (elevated)	0.6 mph	0.6 mph	0.6 mph
Raise/lower time	45/30 sec	50/35 sec	55/40 sec
Gradeability	50%	50%	50%
Max. stabilizer levelling, front to rear	7°	7°	7°
Max. stabilizer levelling, side to side	14°	14°	14°
Inside turning radius	6 ft 8 in	6 ft 8 in	6 ft 8 in
Outside turning radius	17 ft 4 in	17 ft 4 in	17 ft 4 in
Tires	12 x 33 foam filled		
Controls	proportional joystick		
Drive system	4 wheel drive		

POWER	S9033RT*	S9043RT*	S9053RT*
Power source	Kubota diesel		

WEIGHT	S9033RT*	S9043RT*	S9053RT*
Weight	12,000 lbs	14,000 lbs	16,500 lbs

TURNING RADIUS

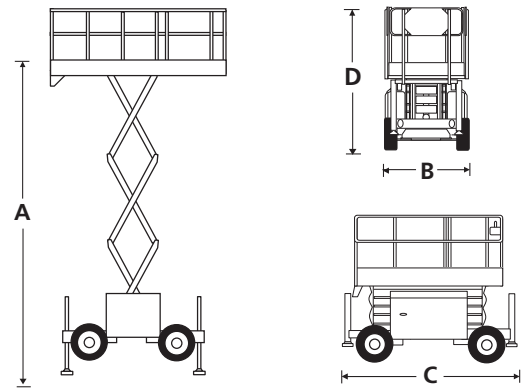
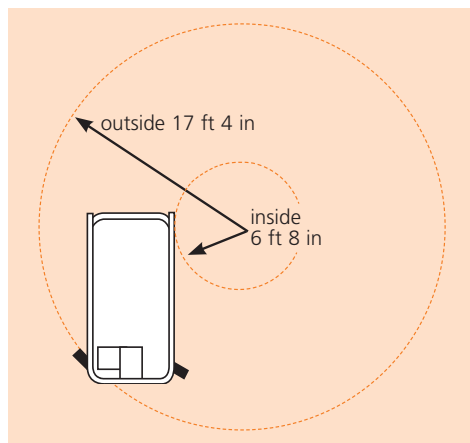

STANDARD FEATURES

- 4 hydraulic stabilizers with automatic levelling (S9053RT only)
- 4 wheel drive
- Single manual roll-out deck extension
- Proportional controls
- Foam filled tires
- Power line to platform
- Drive motion alarm
- Descent alarm
- Locking articulating axle
- Fold-down guardrails
- Manual lowering valve
- Flashing amber light
- Dual lanyard attachment points
- Hour meter & on-board diagnostics display
- 2 year parts & labor, 5 year structural warranty
- ANSI compliant

OPTIONS

- Special paint colors
- Nylon spreader pads (set of 4)
- Environmental hydraulic oil
- Dual fuel
- LPG power
- Cold weather package (block heater + battery warm up)
- Dual extension decks
- Powered extension deck(s)
- Hydraulic generator 2kW
- Hydraulic generator 12kW
- 4 hydraulic stabilizers with automatic levelling (S9033RT & S9043RT)

snorkel www.snorkellifts.com

P.O. Box 1160
St. Joseph, MO 64502-1160, USA
Tel: 1 (785) 989-3000
Toll-free: 1 (800) 255-0317
Fax: 1 (785) 989-3070
Email: sales.usa@snorkellifts.com